



# Model: Z.WC3.S

Zurn One Sensor Floor Mounted Toilet System with 1.1 GPF EcoVantage® Battery Powered Flush Valve

TAG \_\_\_\_\_

### Architectural/Engineering Specification:

Complete EcoVantage® high efficiency 1.1 gpf sensor actuated, battery powered, floor mounted commercial water closet system with ZER6000AV-ONE-CPM exposed, sensor activated chrome plated closet diaphragm flushometer for either left or right hand supply, Z5955SS-EL open front commercial toilet seat and Z5655-BWL1 floor mounted vitreous china water closet with Z5972-COMB closet flange outlet gasket assembly kit manufactured by Zurn Industries.

### Product Features:

- 1.1 gpf (gallons per flush)
- Floor mounted elongated front rim top spud toilet
- High efficiency siphon jet flush action
- 2-1/8" fully glazed trapway
- Large water spot - 12' x 10'
- Vitreous china wall bowl construction
- Diaphragm- type flushometer complete with Zurn's Go Blue® TPE, chloramine resistant, dual seal diaphragm with a clog resistant filtered by-pass.
- High pressure vacuum breaker
- Adjustable tailpiece
- Contol stop with internal siphon guard protection, vandal resistant cap, sweat solder kit and cast wall flange with set screw
- Open front, elongated, white commercial toilet seat with SS check hinges
- 14% water savings over standard 1.28 gpf system
- 31% water savings over standard 1.6 gpf system

### Compliance and Certification:



This system complies with the Buy American Act: Fixture manufactured in China; Valve manufactured in US with US and foreign parts.

Meets the American Disabilities Guidelines and ANSI A117.1 requirements when installed according to these requirements.

Fixture - Complies with ASME A119.2 / CSA B45.1

Faucet - Complies with ASME A112.18.1 / CSA B125.1

ZURN INDUSTRIES, LLC 511 W. Freshwater Way, Milwaukee, WI U.S.A. 53204 · Ph. 1-855-ONE-ZURN, Fax 919-775-3541

In Canada: ZURN INDUSTRIES LIMITED 7900 Goreway Drive, Unit 10, Brampton, Ontario L6T 5W6, Ph. 905-405-8272, Fax 905-405-1292

Rev. A

Date: 08/28/19

C.N. No. NEW

Prod. | Dwg. No. SS Z.WC3.S



### Zurn One System Packout Includes:

#### Water Closet - Z5655-BWL1:

Vitreous China, floor mounted, bottom outlet toilet with siphon jet flushing action and elongated front rim with 1-1/2" spud. This bowl is designed to perform to industry standards with as little as 1.1 gallons per flush.

#### Flush Valve - ZER600AV-ONE-CPM:

Exposed, quiet diaphragm-type, chrome plated flushometer valve with a polished exterior. Complete with Zurn's AquaVantage® TPE, chloramine resistant, dual seal diaphragm with a clog resistant, filtered bypass. The valve incorporates a 6VDC motor actuator, a battery powered automatic sensor, high impact resistant polycarbonate housing and chrome plated plastic cover with manual override push button and 10 degree angled sensor.

#### Z5955SS-EL:

Elongated, open front white toilet seat with stainless steel check hinges

#### Z5972-COMB:

Closet bolt/wax ring kit

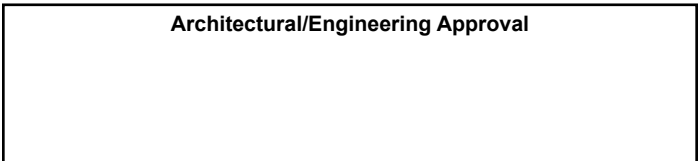

The information contained in this document is subject to change without notice. Please contact Zurn for most up to date information.



US 1.855.ONE.ZURN CANADA 1.905.405.8272 ZURN.COM



# Model: Z.WC3.S

Zurn One Sensor Floor Mounted Toilet System with  
1.1 GPF EcoVantage® Battery Powered Flush Valve

TAG \_\_\_\_\_

## Rough-in Dimensions

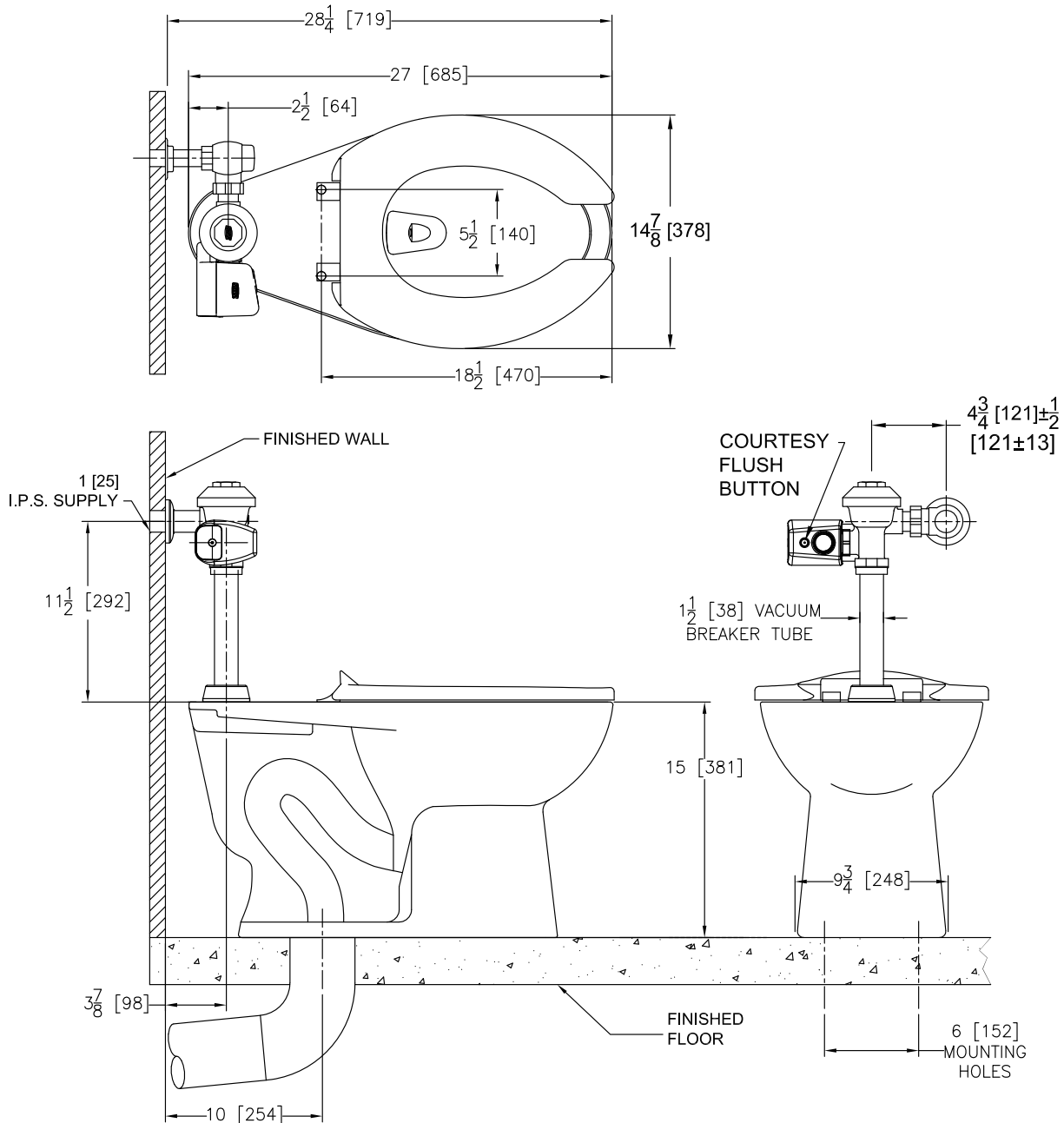

**This system complies with the Buy American Act:** Fixture manufactured in China; Valve manufactured in US with US and foreign parts.

Meets the American Disabilities Guidelines and ANSI A117.1 requirements when installed according to these requirements.

Fixture - Complies with ASME A119.2 / CSA B45.1

Faucet - Complies with ASME A112.18.1 / CSA B125.1